

PLUS SV/SL/SLX



PLUS SV



PLUS 3-5-7 SL



PLUS 9-18 SL



PLUS SLX



Pompe centrifughe multistadio verticali. Adatte alla movimentazione di liquidi non carichi; sistemi di pressurizzazione; irrigazione; acque potabili o con glicole in soluzione; trattamento acque; industria alimentare; riscaldamento e condizionamento; sistemi di lavaggio.

Stainless steel multistage vertical pumps. Pumping of clean non-loaded fluids; pressurizing system; irrigation; drinking and glycol water; water treatment; food industry; heating and air conditioning; washing system.

Bombas centrífugas multietapas verticales. Bombeo de líquidos químicamente y mecánicamente no agresivos; sistemas de presurización; riego; agua potable o con glicol; tratamientos del agua; industria alimenticia; calefacción y refrigeración; sistemas de lavado.

Pompes centrifuges multicellulaires verticales. Pompage d'eaux propres non chargées; groupes de surpression; irrigation; eau potable ou solution de glycol; traitement des eaux; industrie alimentaire; chauffage et climatisation; stations de lavage auto.

CARATTERISTICHE COSTRUTTIVE / CONSTRUCTION FEATURES CARACTERÍSTICAS CONSTRUCTIVAS / CARACTÉRISTIQUES D'EXÉCUTION

Corpo pompa Pump body	ghisa (SV/SL); acciaio cromo-nickel AISI 304 (SLX) cast iron (SV/SL); stainless steel AISI 304 (SLX)
Cuerpo bomba Corps de pompe	fundición (SV/SL); acero cromo-nickel AISI 304 (SLX) fonte (SV/SL); acer chrome-nickel AISI 304 (SLX)
Supporto motore Motor bracket	ghisa cast iron
Soporte motor Support moteur	fundición fonte
Giranti, diffusori, camicia, albero motore Impellers, diffusers, shell, motor shaft	acciaio cromo-nickel AISI 304 stainless steel AISI 304
Rodetes, difusores, camisa, eje motor Turbines, diffuseurs, chemise, arbre moteur	acero cromo-niquel AISI 304 acier chrome-nickel AISI 304
Tenuta meccanica Mechanical seal	ceramica-grafite ≤ 6 giranti grafite-carburo di silicio ≥ 7 giranti ceramic-graphite ≤ 6 impellers graphite-silicon carbide ≥ 7 impellers
Sello mecánico Garniture mécanique	cerámica-grafito ≤ 6 rodetes grafito-carburo de silicio ≥ 7 rodetes céramique-graphite ≤ 6 turbines graphite-carbure de silicium ≥ 7 turbines
Cuscinetto intermedio guida albero Intermediate shaft guiding stage bush	ceramica-carburo di tungsteno ceramic-tungsten carbide
Cojinete intermedio guía-eje Douilles étage de guidage intermédiaire	ceramica-carburo de tungsteno céramique-carbure de tungstène
Temperatura ambiente Ambient temperature	max 40 °C
Temperatura del ambiente Température ambiante	
Temperatura del liquido Liquid temperature	
Temperatura del liquido Température du liquide	+5 ÷ 90 °C (SV) -15 ÷ 110 °C (SL/SLX)
Pressione max di esercizio Max operating pressure	8 bar ≤ 6 giranti; 14 bar ≥ 7 giranti 8 bar ≤ 6 impellers; 14 bar ≥ 7 impellers
Presión max de trabajo Pression max de fonctionnement	8 bar ≤ 6 rodetes; 14 bar ≥ 7 rodetes 8 bar ≤ 6 turbines; 14 bar ≥ 7 turbines
Guarnizione corpo pompa Pump body gasket	EPDM
Guarniciones cuerpo bomba Joint corps de pompe	

MOTORE / MOTOR / MOTOR / MOTEUR

Motore 2 poli a induzione 2 pole induction motor	3~ 230/400V-50Hz P ≤ 4kW 3~ 400/690V-50Hz P > 4kW
Motor de 2 polos a inducción Moteur à induction à 2 pôles	1~ 230V-50Hz (con termoprotettore fino a 1,85kW with thermal protection up to 1,85 kW con protección térmica hasta 1,85 kW avec protection thermique jusqu'à 1,85 kW)
Classe di isolamento Insulation class	F
Clase de aislamiento Classe d'isolation	
Grado di protezione Protection degree	
Grado de protección Protection	IP44 IP55 ≥ 4,5 HP

P 3 S V/ X - 100/5 T

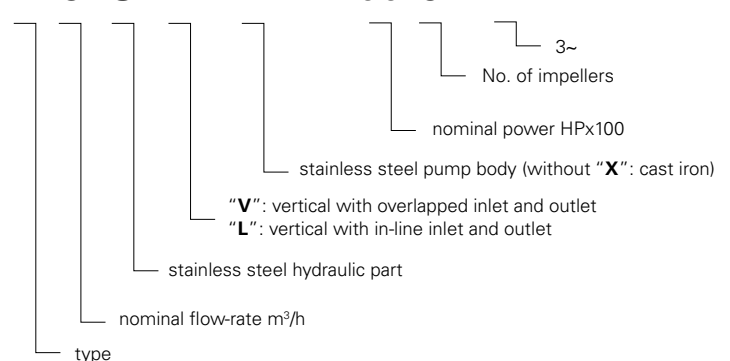

3 SV/SL/SLX

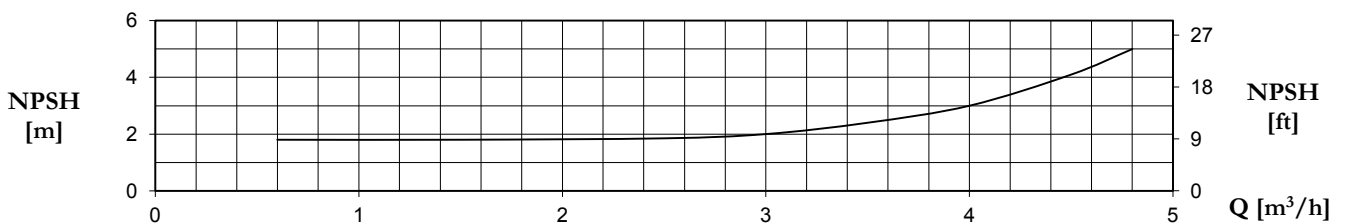
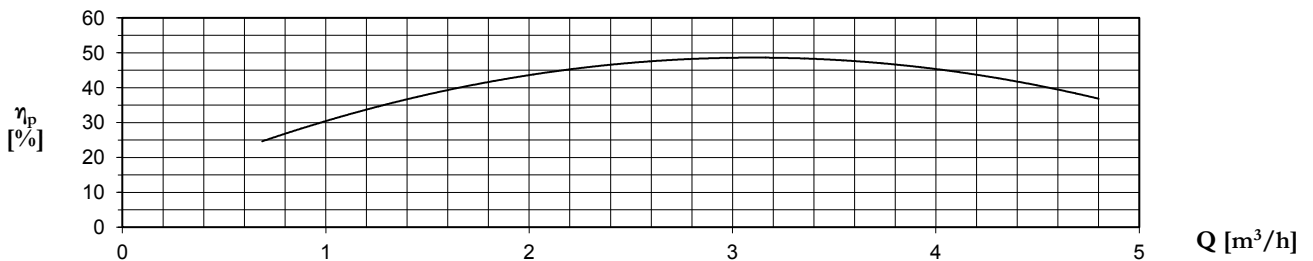
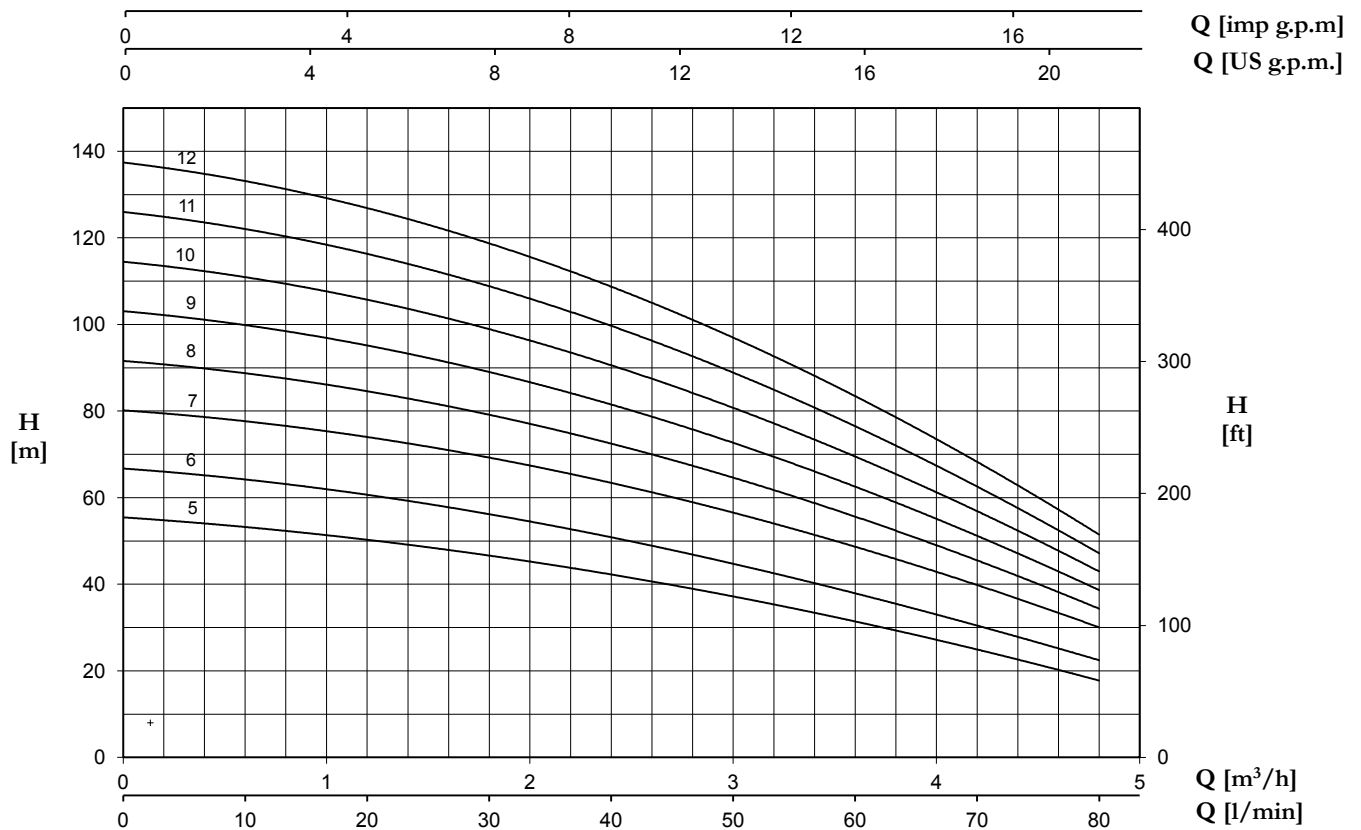

P 3... SV/SL/SLX		P2		P1 (kW)		AMPERE		Q (m³/h - l/min)						
1~	3~					1~	3~	0	0,6	1,2	1,8	2,4	3,6	4,8
		(HP)	(kW)	1~	3~	1x230 V 50 Hz	3x400 V 50 Hz	H (m)						
P 3...-100/5	P 3...-100/5T	1	0,75	1	0,9	4,4	1,7	55,3	53,5	50,3	46,5	42,1	31,6	17,7
P 3...-120/6	P 3...-120/6T	1,2	0,9	1,1	1,1	5,1	2,5	66,6	64,4	60,8	56,0	50,7	38,1	22,4
P 3...-150/7	P 3...-150/7T	1,5	1,1	1,4	1,3	6,4	2,7	80,1	77,7	74,2	69,1	63,3	48,8	30,0
P 3...-180/8	P 3...-180/8T	1,8	1,3	1,6	1,5	6,9	2,7	91,5	88,8	84,8	79,0	72,3	55,8	34,3
P 3...-200/9	P 3...-200/9T	2	1,5	1,7	1,6	7,7	3,0	103,0	99,9	95,4	88,8	81,4	62,7	38,6
P 3...-250/10	P 3...-250/10T	2,5	1,8	1,9	1,8	9,2	3,7	114,4	111,0	106,0	98,7	90,4	69,7	42,9
P 3...-280/11	P 3...-280/11T	2,8	2,1	2,1	2,0	9,7	3,9	125,9	122,1	116,6	108,6	99,5	76,7	47,1
P 3...-300/12	P 3...-300/12T	3	2,2	2,3	2,2	10,3	4,3	137,3	133,2	127,2	118,5	108,5	83,7	51,4

5 SV/SL/SLX

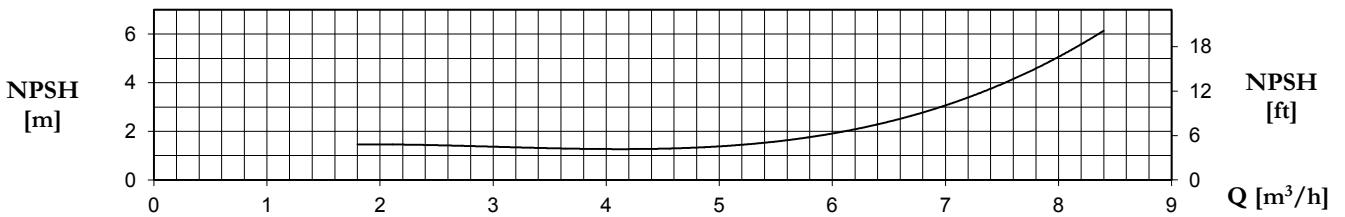
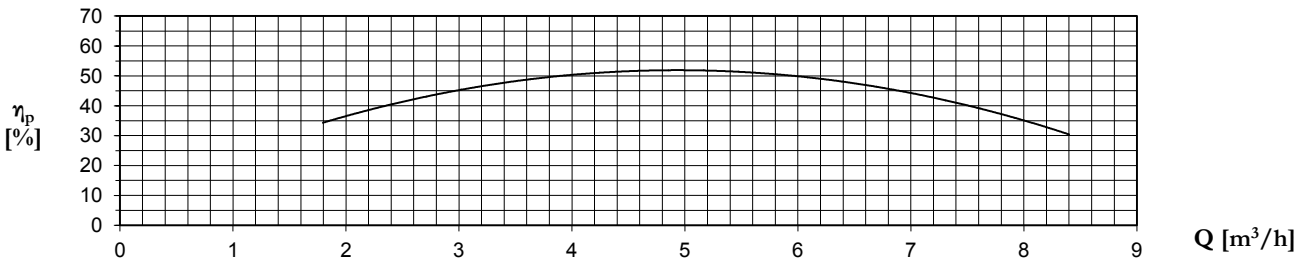
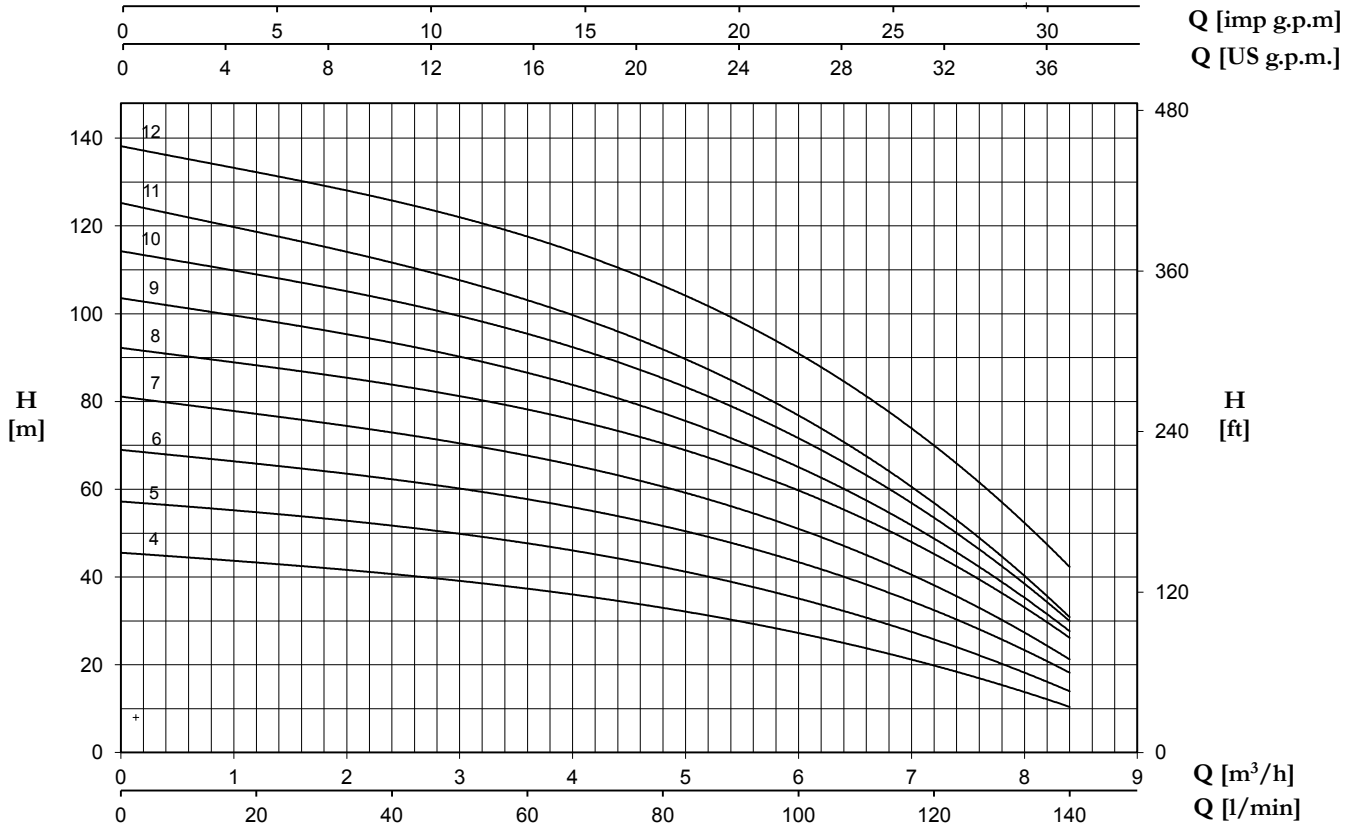

P 5... SV/SL/SLX		P2		P1 (kW)		AMPERE		Q (m³/h - l/min)							
1~	3~	(HP)	(kW)	1~	3~	1~	3~	0	1,8	2,4	3,6	4,8	6	7,2	8,4
								0	30	40	60	80	100	120	140
						1x230 V 50 Hz	3x400 V 50 Hz	H (m)							
P 5...-120/4	P 5...-120/4T	1,2	0,9	1,09	1,09	4,9	2,4	45,5	42,2	40,7	37,2	32,9	27,4	19,8	10,4
P 5...-150/5	P 5...-150/5T	1,5	1,1	1,39	1,31	6,5	2,7	57,2	53,4	51,7	47,6	42,3	35,2	25,7	14,0
P 5...-180/6	P 5...-180/6T	1,8	1,3	1,63	1,55	7,3	3	68,9	64,4	62,3	57,5	51,5	43,5	32,6	18,1
P 5...-200/7	P 5...-200/7T	2	1,5	1,94	1,77	8,7	3,3	81	75,5	73,0	67,4	60,3	51,0	38,6	21,0
P 5...-250/8	P 5...-250/8T	2,5	1,9	2,2	2,07	10,1	4	92,1	86,5	84,0	77,8	70,1	60	45,5	26
P 5...-280/9	P 5...-280/9T	2,8	2,1	2,45	2,27	11	4,2	103,4	96,7	93,5	86	77,1	65,6	48,7	27,6
P 5...-300/10	P 5...-300/10T	3	2,2	2,67	2,57	11,9	4,7	114,2	106,4	102,9	95,2	85,2	72,0	53,3	30
P 5...-350/11	P 5...-350/11T	3,5	2,6	2,85	2,76	12,9	4,9	125,1	115,7	111,8	102,6	91,6	77,1	57,1	30,7
-	P 5...-380/12T	3,8	2,8	-	3,2	-	6,0	138,1	129,4	125,9	117,4	106	91,2	70,1	42,2

7 SV/SL/SLX

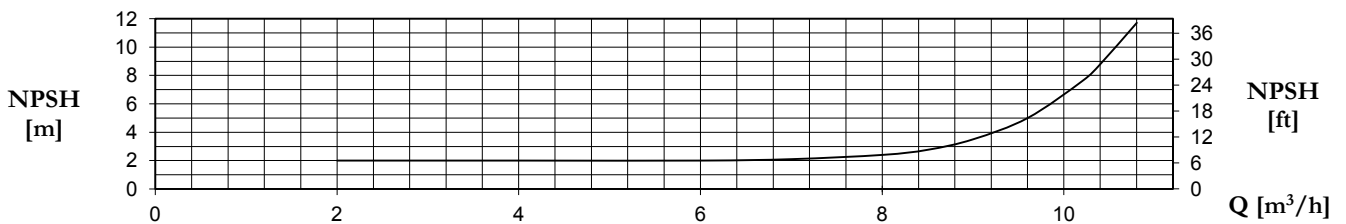
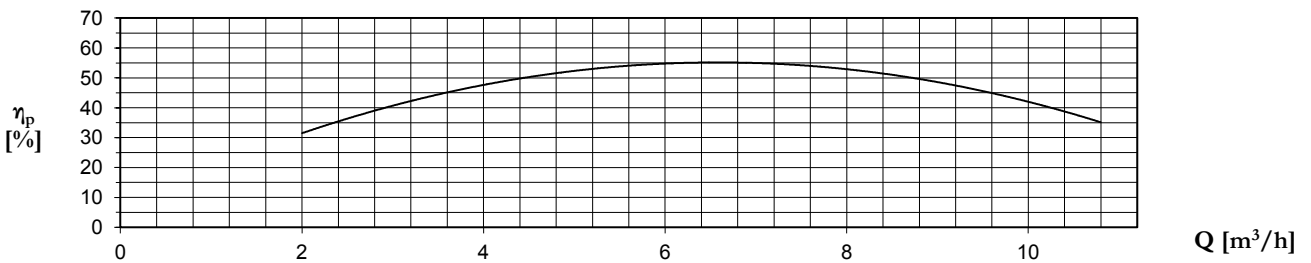
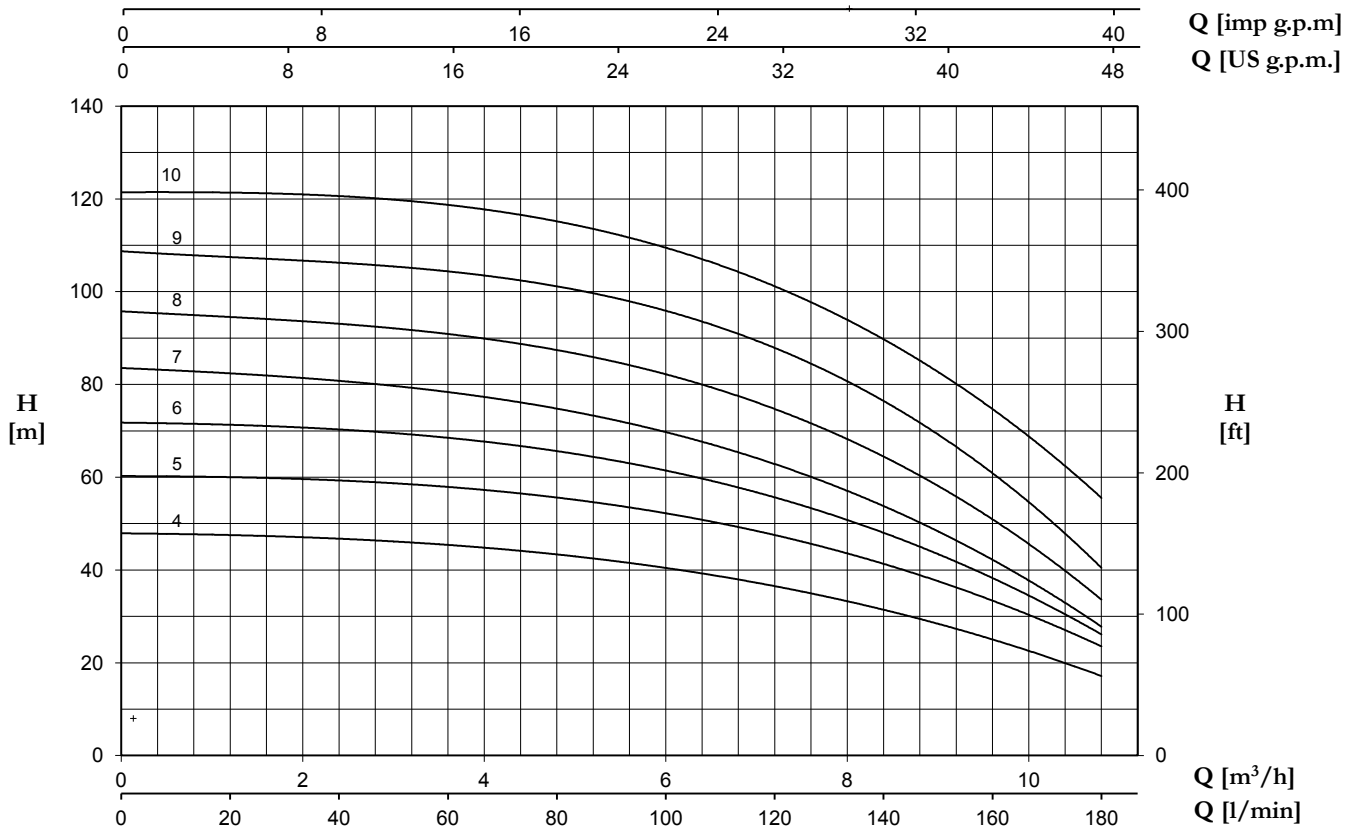

P 7... SV/SL/SLX		P2		P1 (kW)		AMPERE		Q (m³/h - l/min)									
1~	3~					1~	3~	0	2,4	3,6	4,8	6	7,2	8,4	9,6	10,8	
						1x230 V 50 Hz	3x400 V 50 Hz	0	40	60	80	100	120	140	160	180	
		(HP)	(kW)	1~	3~	H (m)											
P 7...-180/4	P 7...-180/4T	1,8	1,3	1,69	1,62	7,7	3,1	48,0	46,3	45,7	43,6	40,4	36,4	31,4	25,0	17,2	
P 7...-250/5	P 7...-250/5T	2,5	1,9	2,19	2,05	10,2	4,1	60,3	59,0	58,2	55,7	52,2	47,4	41,3	33,5	23,5	
P 7...-300/6	P 7...-300/6T	3	2,2	2,53	2,44	11,4	4,8	71,8	70,0	68,9	65,7	61,3	55,4	48,1	38,5	26,0	
-	P 7...-350/7T	3,5	2,6	-	2,84	-	5,1	83,5	80,7	78,8	74,7	69,4	62,6	53,9	42,7	27,5	
-	P 7...-400/8T	4	3	-	3,3	-	6	95,6	93,3	91,4	87,2	81,6	74,2	64,8	51,9	33,0	
-	P 7...-450/9T	4,5	3,4	-	3,81	-	6,5	108,5	106,5	105,1	101,0	95,0	87,2	76,6	62,6	39,5	
-	P 7...-550/10T	5,5	4	-	4,32	-	7,9	121,5	120,1	119,3	115,3	109,2	100,8	89,8	75,0	55,4	

9 SV/SL/SLX

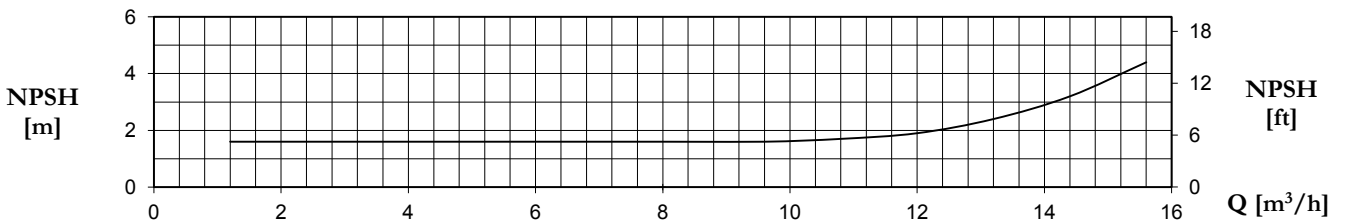
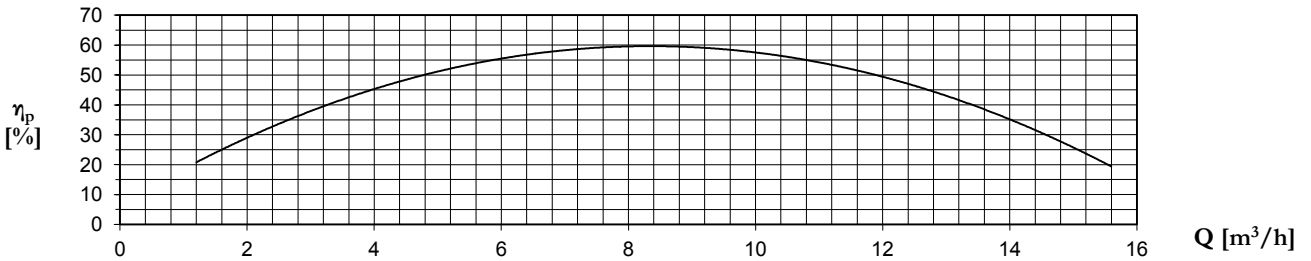
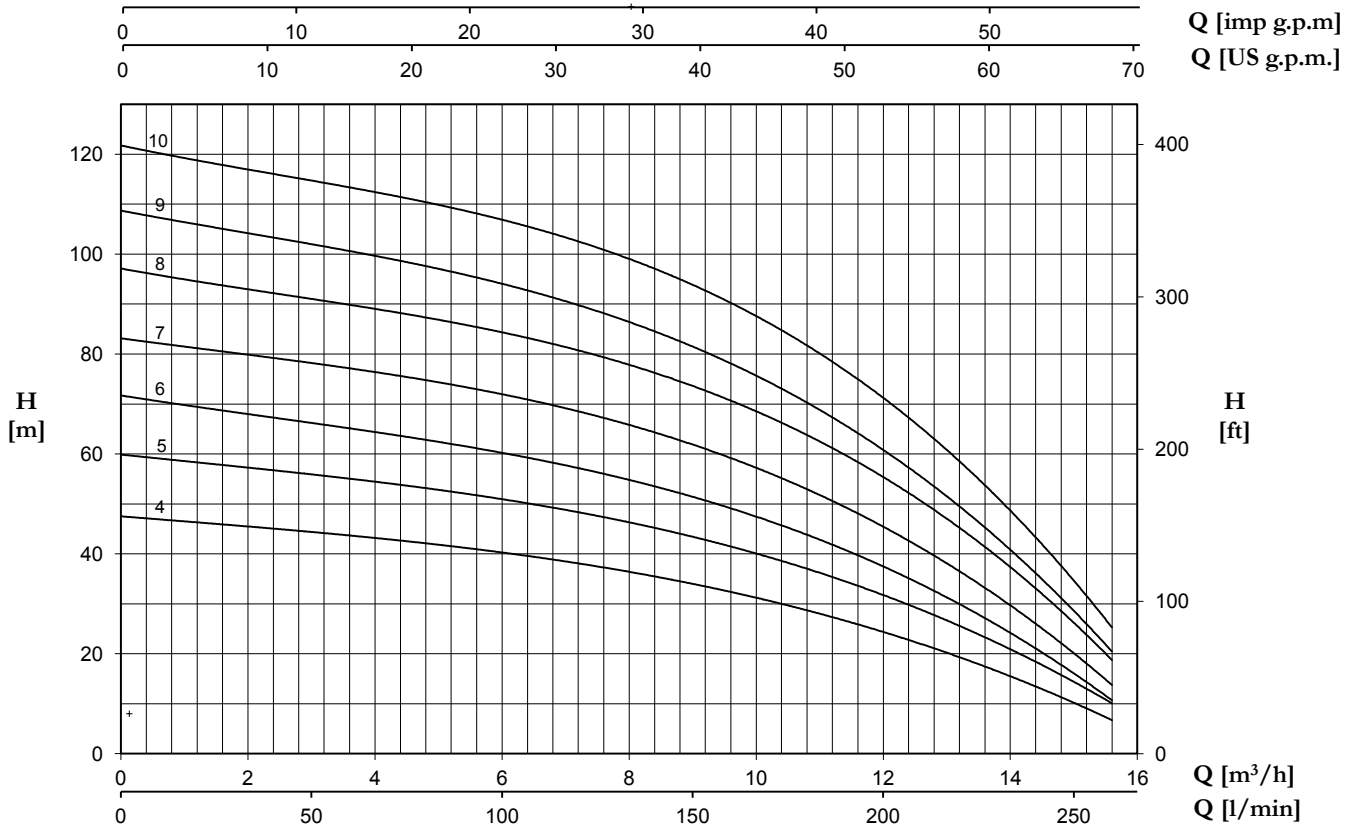

P 9... SV/SL/SLX		P2		P1 (kW)		AMPERE		Q (m³/h - l/min)														
1~	3~	(HP) (kW)		1~ 3~		1~ 3~		0	3,6	4,8	6	7,2	8,4	9,6	10,8	12	13,2	14,4	15,6			
						50 Hz	50 Hz	0	60	80	100	120	140	160	180	200	220	240	260			
								H (m)														
P 9...-200/4	P 9...-200/4T	2	1,5	1,88	1,77	8,4	3,3	47,6	43,5	42,1	40,1	38,1	35,7	32,7	28,9	24,2	19,0	13,1	7,1			
P 9...-250/5	P 9...-250/5T	2,5	1,87	2,36	2,23	10,8	4,3	60	54,8	53,0	51	48,2	45,4	42	37,3	31,6	25	18,0	10,6			
P 9...-300/6	P 9...-300/6T	3	2,2	2,78	2,58	12,5	4,9	71,8	64,9	63,0	59,9	57,0	53,7	49,7	44,3	37,0	29,5	20,8	11,1			
-	P 9...-400/7T	4	3	-	3,13	-	5,8	83,3	76,7	74,9	71,8	68,3	64,6	59,9	53,5	44,8	35,9	25,7	14,3			
-	P 9...-450/8T	4,5	3,37	-	3,72	-	6,4	97,3	89,5	87,3	84	80,5	76,5	71,6	64,8	54,9	44,0	32,4	19,7			
-	P 9...-500/9T	5	3,7	-	4,11	-	7	109,0	100,0	97,6	93,6	89,5	85,0	79,4	71,6	60,1	48,0	34,9	21,9			
-	P 9...-550/10T	5,5	4,0	-	4,58	-	8,3	122,0	112,8	110,5	106,5	102,2	97,3	91,6	82,8	70,7	57,1	42,3	26,5			

18 SV/SL/SLX

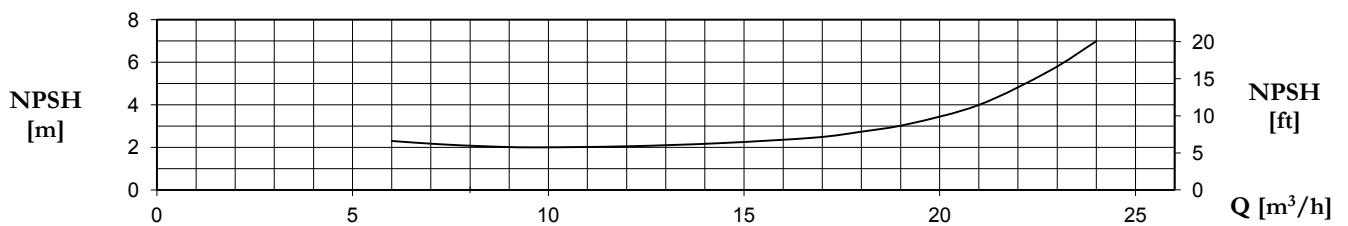
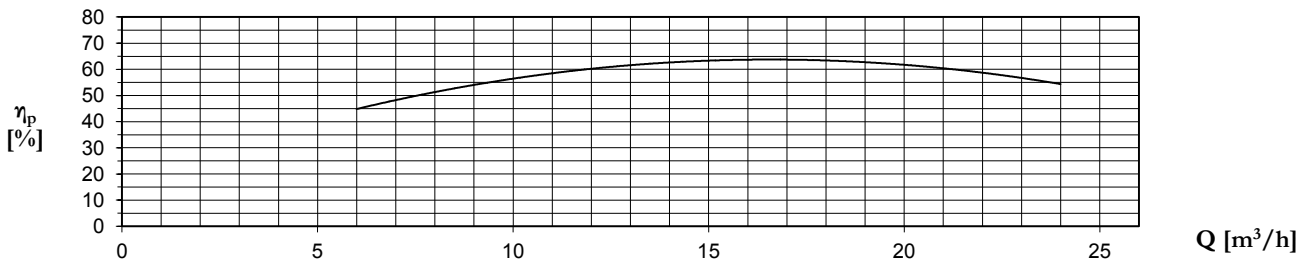
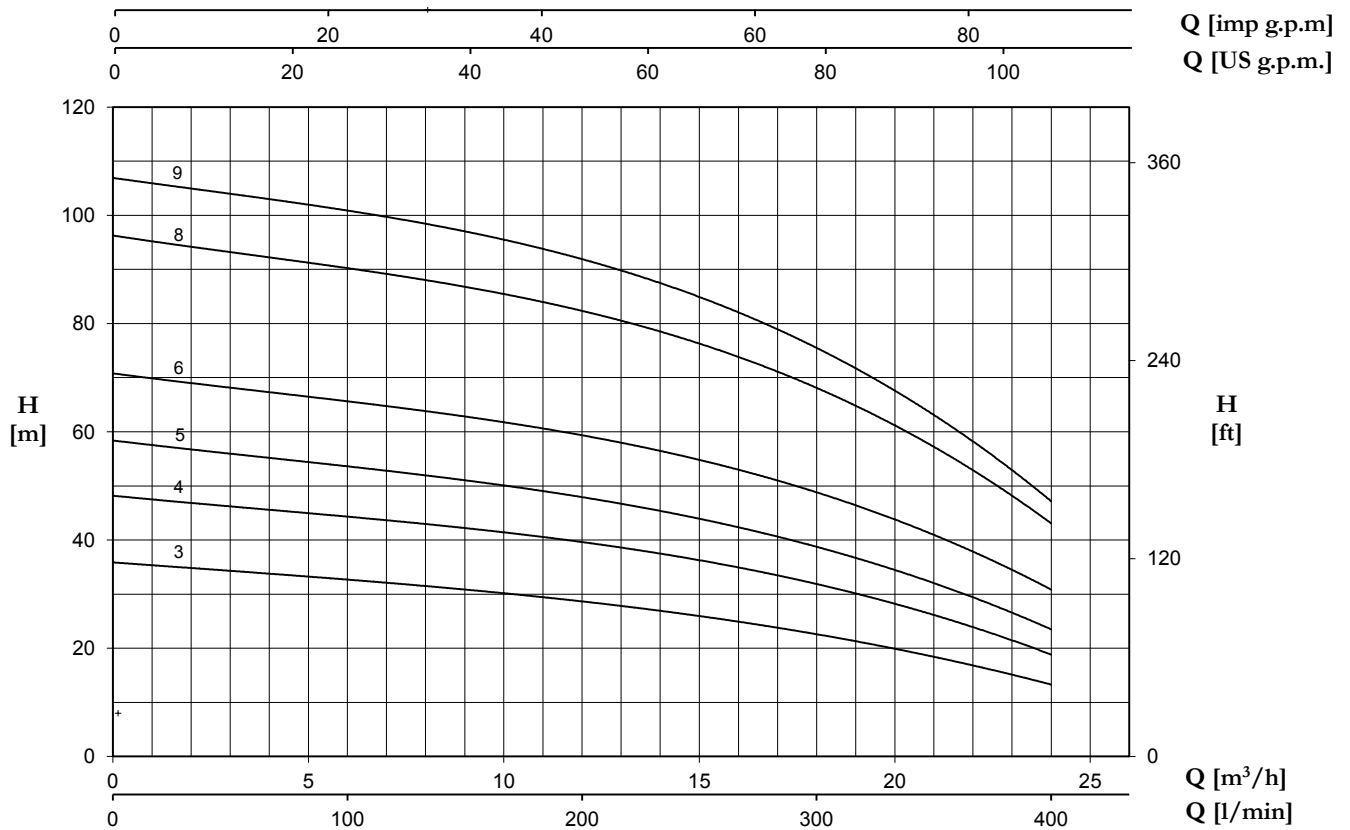

P 18... SV/SL/SLX	P2		P1 (kW)	A																	
				Q (m³/h - l/min)																	
				H (m)																	
3~	(HP)	(kW)	3~	0	6	7,2	8,4	9,6	10,8	12	13,2	14,4	15,6	16,8	18	19,2	20,4	21,6	22,8	24	
				0	100	120	140	160	180	200	220	240	260	280	300	320	340	360	380	400	
P 18...-250/3T	2,5	1,85	2,29	4,4	35,7	33,1	32,3	31,3	30,4	29,4	28,4	27,4	26,3	25,1	24	22,8	21,4	19,6	17,8	15,4	12,9
P 18...-400/4T	4	3	3,11	5,7	47,9	45	44	42,8	41,7	40,5	39,1	37,8	36,6	35,2	33,9	32,2	30,2	28,0	25,1	22,1	18,1
P 18...-450/5T	4,5	3,31	3,79	6,7	58,1	54,3	53,1	51,8	50,4	49,0	47,4	45,9	44,3	42,7	41,0	39,2	37,0	34,0	30,8	26,9	23,0
P 18...-550/6T	5,5	4	4,63	8,7	70,5	66,4	65,0	63,6	62,0	60,5	58,9	57,2	55,4	53,5	51,5	49,3	46,3	43,3	39,4	34,9	30,4
P 18...-750/8T	7,5	5,5	6,15	10,9	95,9	90,9	89,58	88,0	86,1	83,9	81,6	79,5	76,8	74,4	71,8	68,5	65,0	60,4	55,2	49,0	42,2
P 18...-900/9T	9	6,6	7	12,7	106,4	101,8	100,4	98,6	96,1	93,5	91,0	88,2	85,5	82,7	79,7	76,2	72,1	66,9	60,8	53,7	46,1

PLUS SV/SL/SLX

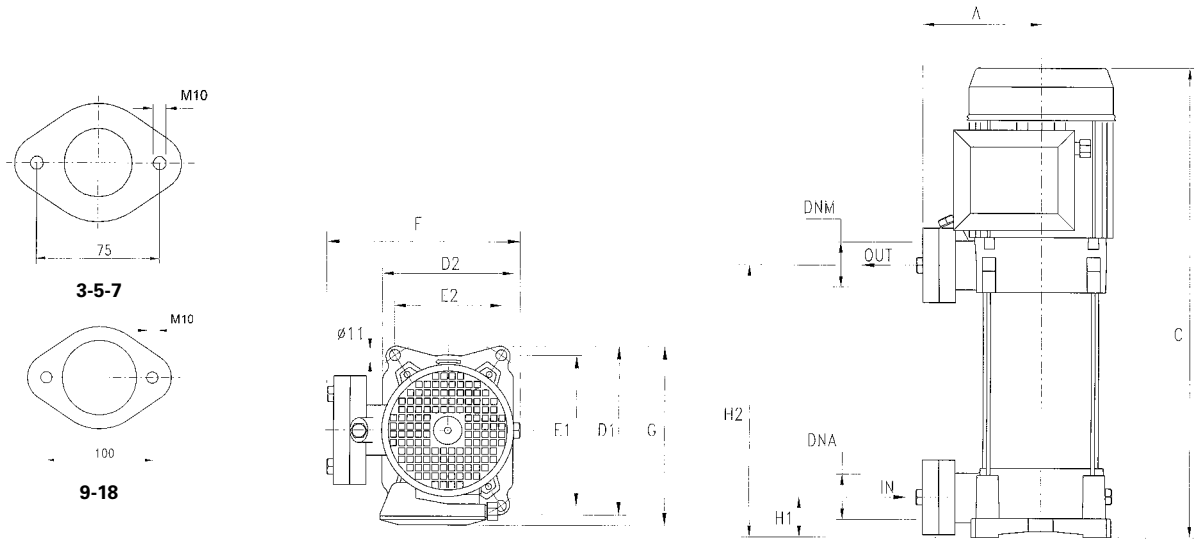

P 3SV	DIMENSIONS (mm)										Kg	DNA	DNM
	A	C	D1	D2	E1	E2	F	G	H1	H2			
P 3SV-100/5	135	413	204	162	178,5	125	229	213	40	178	18,5	1"1/4G	1"1/4G
P 3SV-120/6	135	437	204	162	178,5	125	229	213	40	202	19,5		
P 3SV-150/7	135	491	204	162	178,5	125	229	220	40	226	22,5		
P 3SV-180/8	135	515	204	162	178,5	125	229	220	40	250	24		
P 3SV-200/9	135	539	204	162	178,5	125	229	220	40	274	25,5		
P 3SV-250/10	135	563	204	162	178,5	125	229	220	40	298	26,5		
P 3SV-280/11	135	M 632 T 587	204	162	178,5	125	229	M 228 T 220	40	322	M 29 T 26,5		
P 3SV-300/12	135	M 656 T 611	204	162	178,5	125	229	M 228 T 220	40	346	M 29,5 T 28		

P 5SV	DIMENSIONS (mm)										Kg	DNA	DNM
	A	C	D1	D2	E1	E2	F	G	H1	H2			
P 5SV-120/4	135	389	204	162	178,5	125	229	213	40	178	18,5	1"1/4G	1"1/4G
P 5SV-150/5	135	443	204	162	178,5	125	229	220	40	202	21,5		
P 5SV-180/6	135	467	204	162	178,5	125	229	220	40	226	23,5		
P 5SV-200/7	135	491	204	162	178,5	125	229	220	40	250	24		
P 5SV-250/8	135	515	204	162	178,5	125	229	220	40	274	25,5		
P 5SV-280/9	135	M 584 T 539	204	162	178,5	125	229	M 228 T 220	40	298	M 28 T 25		
P 5SV-300/10	135	M 608 T 563	204	162	178,5	125	229	M 228 T 220	40	322	M 28,5 T 26,5		
P 5SV-350/11	135	632	204	162	178,5	125	229	228	40	346	31,5		
P 5SV-380/12	135	656	204	162	178,5	125	229	228	40	370	32		

P 7SV	DIMENSIONS (mm)										Kg	DNA	DNM
	A	C	D1	D2	E1	E2	F	G	H1	H2			
P 7SV -180/4	135	419	204	162	178,5	125	229	220	40	178	22	1"1/4G	1"1/4G
P 7SV -250/5	135	443	204	162	178,5	125	229	220	40	202	24		
P 7SV -300/6	135	M 512 T 467	204	162	178,5	125	229	M 228 T 220	40	226	M 26 T 24,5		
P 7SV -350/7	135	536	204	162	178,5	125	229	228	40	250	26,5		
P 7SV -400/8	135	560	204	162	178,5	125	229	228	40	274	30		
P 7SV -450/9	135	617	204	162	178,5	125	235	243	40	301	34,5		
P 7SV -550/10	135	641	204	162	178,5	125	235	243	40	325	38		

P 9SV	DIMENSIONS (mm)										Kg	DNA	DNM
	A	C	D1	D2	E1	E2	F	G	H1	H2			
P 9SV -200/4	135	443	204	162	178,5	125	229	220	40	202	23	1"1/2G	1"1/4G
P 9SV -250/5	135	473	204	162	178,5	125	229	220	40	232	24,5		
P 9SV -300/6	135	M 548 T 503	204	162	178,5	125	229	M 228 T 220	40	262	M 26,5 T 26,5		
P 9SV -400/7	135	578	204	162	178,5	125	229	228	40	292	30		
P 9SV -450/8	135	641	204	162	178,5	125	235	243	40	325	34,5		
P 9SV -500/9	135	671	204	162	178,5	125	235	243	40	355	35		
P 9SV -550/10	135	701	204	162	178,5	125	235	243	40	385	38,5		

P 18SV	DIMENSIONS (mm)										Kg	DNA	DNM
	A	C	D1	D2	E1	E2	F	G	H1	H2			
P 18SV-250/3T	135	451	204	162	178,5	125	229	220	50	211	24	2" G	1"1/2G
P 18SV-400/4T	135	534	204	162	178,5	125	229	228	50	248	30		
P 18SV-450/5T	135	605	204	162	178,5	125	235	243	50	289	35		
P 18SV-550/6T	135	642	204	162	178,5	125	235	243	50	326	38,5		
P 18SV-750/8T	135	763	204	162	178,5	125	255	253	50	401	49,5		
P 18SV-900/9T	135	801	204	162	178,5	125	255	253	50	439	53		

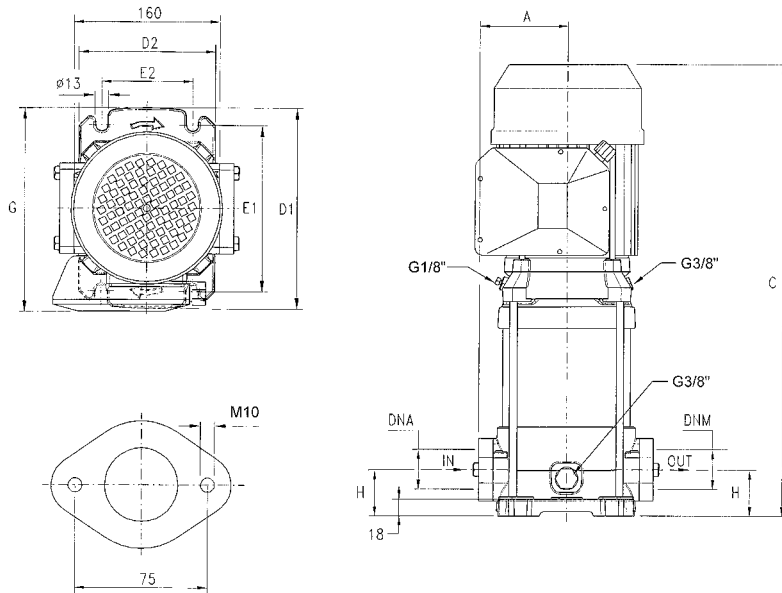

P 3SL / SLX	DIMENSIONS (mm)								Kg		DNA	DNM
	A	C	D1	D2	E1	E2	G	H	SL	SLX		
P 3SL/SLX-100/5	98	429	220	150	180	100	228	50	20	25	1"1/4G	1"1/4G
P 3SL/SLX-120/6	98	453	220	150	180	100	228	50	21,5	26		
P 3SL/SLX-150/7	98	507	220	150	180	100	228	50	24,5	29,5		
P 3SL/SLX-180/8	98	531	220	150	180	100	228	50	26	31		
P 3SL/SLX-200/9	98	555	220	150	180	100	228	50	27,5	32,5		
P 3SL/SLX-250/10	98	579	220	150	180	100	228	50	29	34		
P 3SL/SLX-280/11	98	M 648 T 603	220	150	180	100	M 236 T 228	50	M 31,5 T 28,5	M 36,5 T 33,5		
P 3SL/SLX-300/12	98	M 672 T 627	220	150	180	100	M 236 T 228	50	M 32 T 30	M 36,5 T 35		

P 5SL / SLX	DIMENSIONS (mm)								Kg		DNA	DNM
	A	C	D1	D2	E1	E2	G	H	SL	SLX		
P 5SL / SLX -120/4	98	405	220	150	180	100	221	50	20	25	1"1/4G	1"1/4G
P 5SL / SLX -150/5	98	459	220	150	180	100	228	50	23,5	28,5		
P 5SL / SLX -180/6	98	483	220	150	180	100	228	50	25	30		
P 5SL / SLX -200/7	98	507	220	150	180	100	228	50	26	31		
P 5SL / SLX -250/8	98	531	220	150	180	100	228	50	27,5	32,5		
P 5SL / SLX -280/9	98	M 600 T 555	220	150	180	100	M 236 T 228	50	M 30 T 26,5	M 35 T 32,5		
P 5SL / SLX -300/10	98	M 624 T 579	220	150	180	100	M 236 T 228	50	M 30,5 T 29	M 35,5 T 34		
P 5SL / SLX -350/11	98	648	220	150	180	100	236	50	34	39		
P 5SL / SLX -380/12	98	672	220	150	180	100	236	50	35,4	39,5		

P 7SL / SLX	DIMENSIONS (mm)								Kg		DNA	DNM
	A	C	D1	D2	E1	E2	G	H	SL	SLX		
P 7SL / SLX -180/4	98	435	220	150	180	100	228	50	24	28,5	1"1/4G	1"1/4G
P 7SL / SLX -250/5	98	459	220	150	180	100	228	50	26	31		
P 7SL / SLX -300/6	98	M 528 T 483	220	150	180	100	M 236 T 228	50	M 28,5 T 26,5	M 33,5 T 31		
P 7SL / SLX -350/7	98	552	220	150	180	100	236	50	29	34		
P 7SL / SLX -400/8	98	576	220	150	180	100	236	50	32	37		
P 7SL / SLX -450/9	98	633	220	150	180	100	251	50	36,5	41,5		
P 7SL / SLX -550/10	98	657	220	150	180	100	251	50	40	45		

PLUS SV/SL/SLX

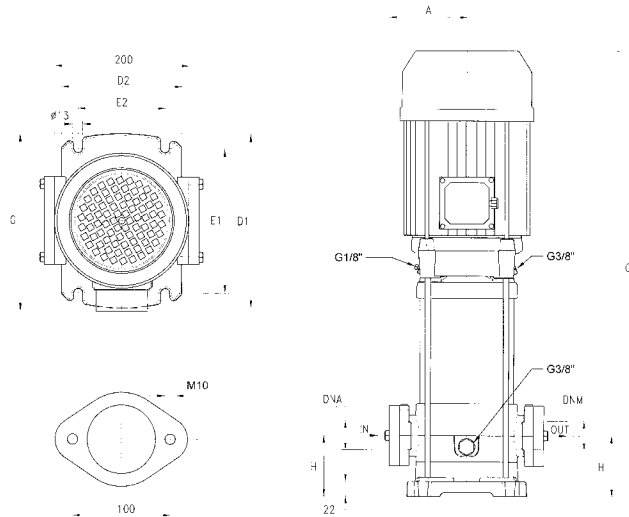

P 9SL / SLX	DIMENSIONS (mm)								Kg		DNA	DNM
	A	C	D1	D2	E1	E2	G	H	SL	SLX		
P 9SL / SLX -200/4	118	490	260	180	215	130	248	80	29,5	28	1"1/2G	1"1/2G
P 9SL / SLX -250/5	118	520	260	180	215	130	248	80	31	29,5		
P 9SL / SLX -300/6	118	M 595 T 550	260	180	215	130	M 256 T 248	80	M 33,5 T 31,5	M 31,5 T 30		
P 9SL / SLX -400/7	118	625	260	180	215	130	256	80	36,5	35		
P 9SL / SLX -450/8	118	688	260	180	215	130	271	80	40,5	39		
P 9SL / SLX -500/9	118	718	260	180	215	130	271	80	41,5	39,5		
P 9SL / SLX -550/10	118	748	260	180	215	130	271	80	45	43		

P 18SL / SLX	DIMENSIONS (mm)								Kg		DNA	DNM
	A	C	D1	D2	E1	E2	G	H	SL	SLX		
P 18SL/SLX-250/3T	118	452	260	180	215	130	251	90	29,5	28	2"G	2"G
P 18SL/SLX-400/4T	118	575	260	180	215	130	257	90	35,5	34		
P 18SL/SLX-450/5T	118	646	260	180	215	130	271	90	40	38,5		
P 18SL/SLX-550/6T	118	683	260	180	215	130	271	90	43,5	42,5		
P 18SL/SLX-750/8T	118	804	260	180	215	130	280	90	54	52,5		
P 18SL/SLX-900/9T	118	842	260	180	215	130	280	90	57,5	56,5		

TYPE	TRUCK		CONTAINER	
	PALLET (cm)	N° pumps	PALLET (cm)	N° pumps
P 3SV-100/5-200/9	80X120X150	42	80X120X175	49
P 3SV-250/10-300/12 M	80X120X155	30	80X120X180	35
P 3SV-300/12T	80X120X150	42	80X120X175	49
P 5SV-120/4-250/8	80X120X150	42	80X120X175	49
P 5SV-280/9T-300/10T	80X120X150	42	80X120X175	49
P 5SV-280/9 M-300/10 M	80X120X155	30	80X120X180	35
P 5SV-350/11-380/12T	80X120X155	30	80X120X180	35
P 7SV-180/4-350/7T	80X120X150	42	80X120X175	49
P 7SV-400/8T	80X120X155	30	80X120X180	35
P 7SV-450/9T-550/10T	85X110X125	20	85X110X150	24
P 9SV-200/4	80X120X150	42	80X120X175	49
P 9SV-250/5-300/6T	80X120X150	42	80X120X175	49
P 9SV-300/6 M-400/7T	80X120X155	30	80X120X180	35
P 9SV-450/8T-550/10T	85X110X125	20	85X110X150	24
P 18SV-250/3T-400/4T	80X120X150	42	80X120X175	49
P 18SV-450/5T-550/6T	85X110X125	20	85X110X150	24
P 18SV-750/8T-900/9T	100X120X150	12	100X120X150	12

TYPE	TRUCK		CONTAINER	
	PALLET (cm)	N° pumps	PALLET (cm)	N° pumps
P 3SL/SLX-100/5-180/8	85X110X150	36	85X110X170	42
P 3SL/SLX-200/9-300/12	80x120x150	30	80x120x170	35
P 5SL/SLX-120/4-250/8	85X110X150	36	85X110X170	42
P 5SL/SLX-280/9-380/12T	80x120x150	30	80x120x170	35
P 7SL/SLX-180/4-300/6T	85X110X150	36	85X110X170	42
P 7SL/SLX-300/6 M-400/8T	80x120x150	30	80x120x170	35
P 7SL/SLX-450/9T-550/10T	80x120x150	30	80x120x170	35
P 9SL/SLX-200/4-400/7T	80X120X155	25	80X120X185	30
P 9SL/SLX-450/8T-550/10T	85X110X150	20	85X110X150	20
P 18SL/SLX-250/3T-400/4T	80X120X155	25	80X120X185	30
P 18SL/SLX-450/5T-550/6T	85X110X150	20	85X110X150	20
P 18SL/SLX-750/8T-900/6T	85X110X150	20	85X110X150	20