

FC



FC 160-310



FC 410-1000T



FC 410-1000/PT



Pompe da drenaggio con girante centrifuga che garantisce una elevata prevalenza; adatte ad applicazioni civili e industriali; sono state particolarmente progettate per uso estremamente gravoso; disponibili sia per applicazioni mobili e fissa con piede di accoppiamento.

Centrifugal drainage pump that guarantees high head; ideal for civil and industrial applications; specifically designed for very heavy use; available in the mobile or permanent versions with coupling feet.

Bombas de drenaje con rodete centrífugo que garantiza una elevada prevalencia; apropiadas para aplicaciones civiles e industriales; se han proyectado especialmente para un uso extremadamente gravoso; disponibles para aplicaciones móviles y fija con pie de acoplamiento.

Pompes de drainage avec une roue centrifuge qui garantit une hauteur manométrique élevée; indiquées pour les applications civiles et industrielles; elles ont été spécialement conçues pour un service très intense; disponibles pour applications aussi bien mobiles que fixes, avec pied d'accouplement.

CARATTERISTICHE COSTRUTTIVE / CONSTRUCTION FEATURES CARACTERÍSTICAS CONSTRUCTIVAS / CARACTÉRISTIQUES D'EXÉCUTION

Corpo pompa Pump body Cuerpo bomba Corps de pompe	ghisa cast iron fundición fonte
Girante Impeller Rodete Turbine	ghisa cast iron fundición fonte
Tenuta meccanica Mechanical seal Sello mecánico Garniture mécanique	doppia tenuta con barriera d'olio:carburo di silicio lato pompa, ceramica-grafite lato motore double seal with oil barrier: silicon carbide on pump side, ceramic-graphite on motor side doble sello con cámara interpuesta:carburo de silicio lado bomba, cerámica-grafito lado motor double garniture avec film lubrifiant:carbure de silice côté pompe, céramique-graphite côté moteur
Albero motore Motor shaft Eje motor Arbre moteur	acciaio AISI 304 stainless steel AISI 304 acero AISI 304 acier AISI 304
Passaggio corpi solidi Passage of solids Paso de solidos Passage corps solides	10 mm
Profondità di immersione Depth of immersion Profundidad inmersión Profondeur immersion	max 20 m
Temperatura del liquido Liquid temperature Temperatura del liquido Température du liquide	0 - 40 °C
Cavo Cable Cable Câble	H07 RNF, 10 m
Viteria Bolts Tornillos Vis	acciaio inossidabile A2 A2 stainless steel acero A2 acier A2
Base appoggio Foot support Placa base Plaque de base	ferro zincato galvanized iron hierro galvanizado fer galvanisé
Guarnizioni Gaskets Anilos Joints	gomma NBR NBR rubber goma NBR caoutchouc NBR
MOTORE / MOTOR / MOTOR / MOTEUR	
Motore 2 poli a induzione in bagno d'olio	3~ 230/400V-50Hz P ≤ 4kW 3~ 400/690V-50Hz P > 4kW
2 pole induction motor in oil bath	1~ 230V-50Hz necessario condensatore d'avviamento (35µF per modello da 1,5HP, 50µF per modello da 2HP)
Motor de 2 polos a inducción en baño de caeite	required starter capacitor (35µF for 1,5HP model, 50µF for 2HP model)
Moteur à induction à 2 pôles en bain d'huile	necesario condensador de arranque (35µF para modelo 1,5HP, 50µF para modelo 2HP)
Moteur à induction à 2 pôles en bain d'huile	nécessaires condensateur de démarrage (35µF pour modèle 1,5HP, 50µF pour modèle 2HP)
Classe di isolamento Insulation class Clase de aislamiento Classe d'isolation	F
Grado di protezione Protection degree Grado de protección Protection	IP68

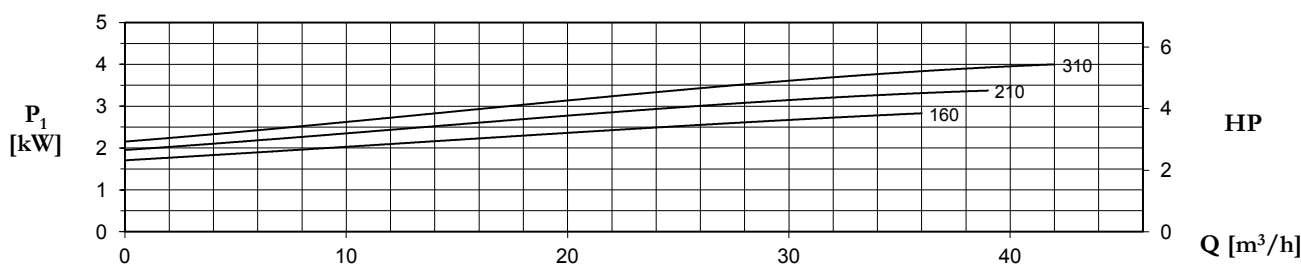
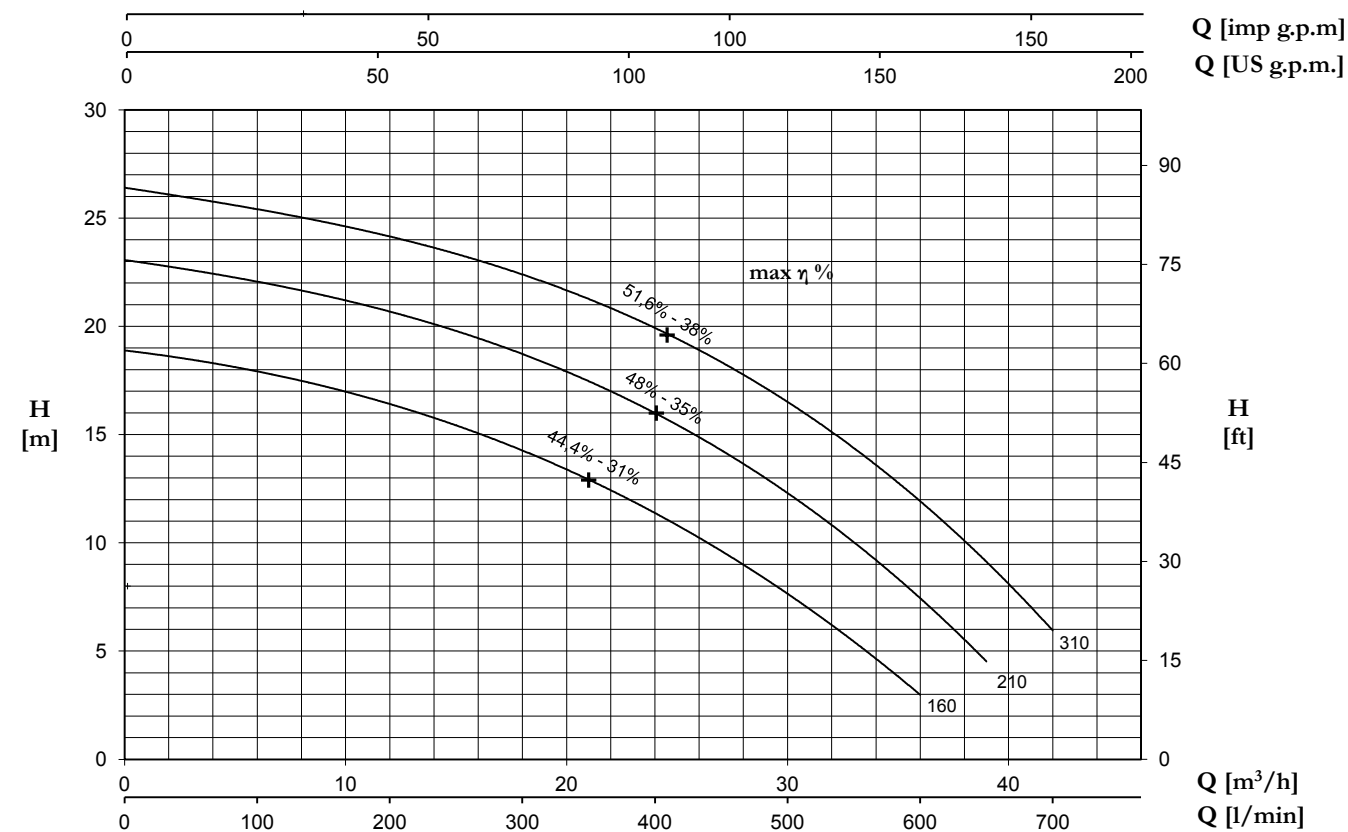

TYPE		AMPERE				
1~	3~	230 V 50 Hz	3x230 V 50 Hz (*)	3x400 V 50 Hz	230/400 V 50 Hz λ / Δ (*)	400/690 V 50 Hz λ / Δ
FC 160	FC 160T	13,8	8,3	4,8	-	-
FC 210	FC 210T	16,5	10,2	5,9	-	-
-	FC 310T	-	12,0	6,9	-	-

+ max η %

max rendimento idraulico e rispettivo rendimento totale
 max hydraulic efficiency and respective total efficiency
 máx rendimiento hidráulico y correspondiente rendimiento total
 max rendement hydraulique et rendement total

(*) no standard execution

TYPE		Q (m³/h - l/min)												
1~	3~	P2		P1 (kW)		0	6	12	18	24	30	36	39	42
		(HP)	(kW)	1~	3~	0	100	200	300	400	500	600	650	700
		H (m)												
FC 160	FC 160T	1,5	1,1	3,0	2,8	18,9	17,9	16,4	14,3	11,4	7,6	3,0	-	-
FC 210	FC 210T	2	1,5	3,7	3,4	23,0	22,2	20,7	18,6	15,9	12,5	7,4	4,5	-
-	FC 310T	3	2,2	-	4,0	26,4	25,4	24,2	22,4	19,9	16,4	12,1	9,1	5,9

FC

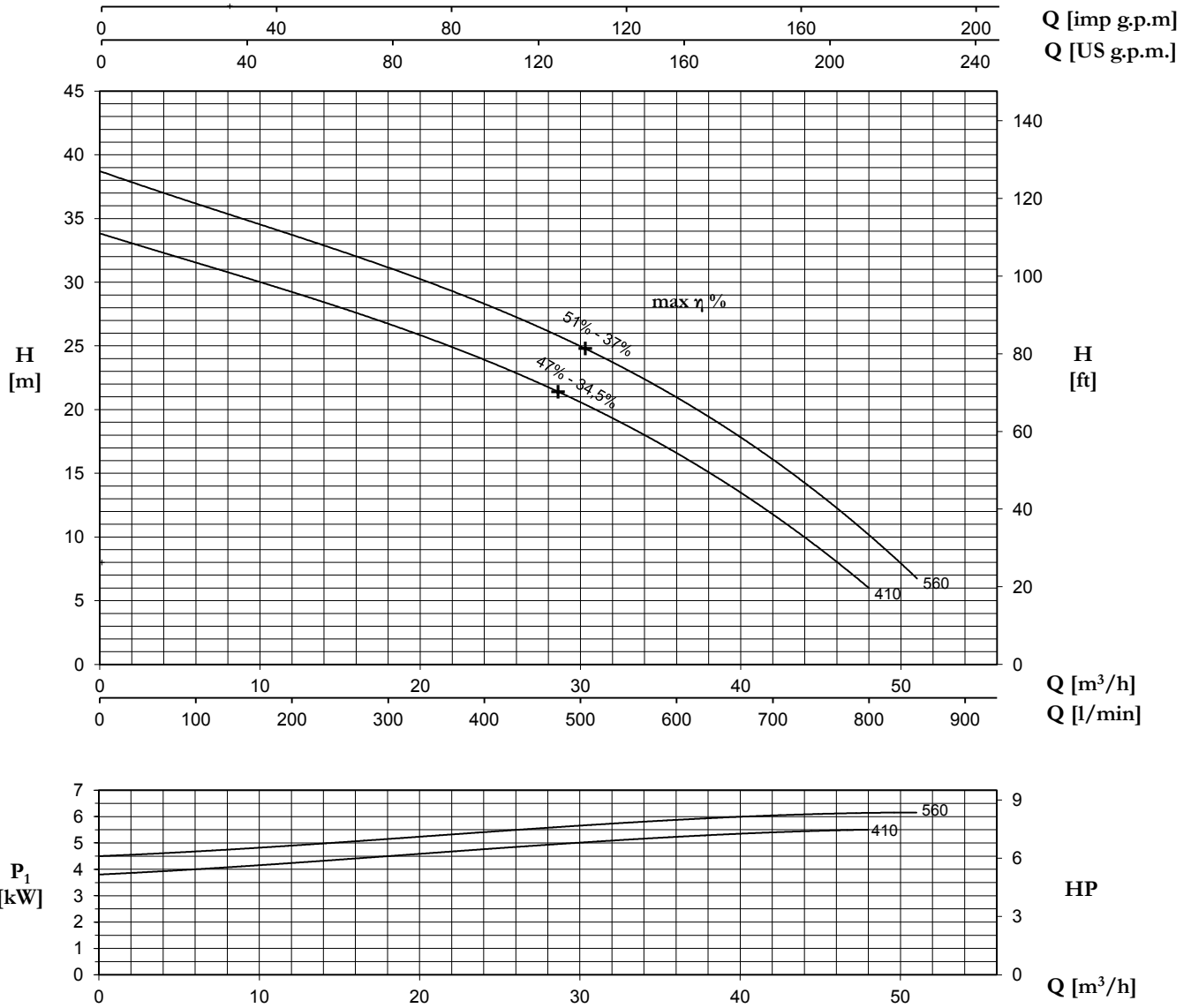

TYPE	AMPERE			
	3x230 V 50 Hz (*)	3x400 V 50 Hz	230/400 V 50 Hz λ / Δ (*)	400/690 V 50 Hz λ / Δ
FC 410T	15,4	8,9	-	-
FC 560T	18,5	10,7	-	-

(*) no standard execution

+ max η %

max rendimento idraulico e rispettivo rendimento totale
 max hydraulic efficiency and respective total efficiency
 máx rendimiento hidráulico y correspondiente rendimiento total
 max rendement hydraulique et rendement total

TYPE	P2		P1 (kW)	Q (m³/h - l/min)									
				0	6	12	18	24	30	36	42	48	51
				0	100	200	300	400	500	600	700	800	850
3~	(HP)	(kW)	3~	H (m)									
FC 410T	4	3	5,5	33,8	31,6	29,2	26,8	23,9	20,5	16,5	12,0	5,9	-
FC 560T	5,5	4	6,3	38,7	36,1	33,9	31,2	28,3	24,7	20,9	16,3	10,4	6,5

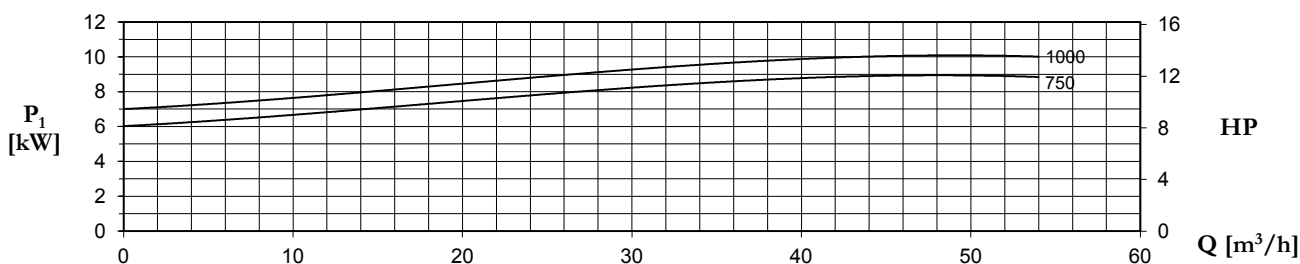
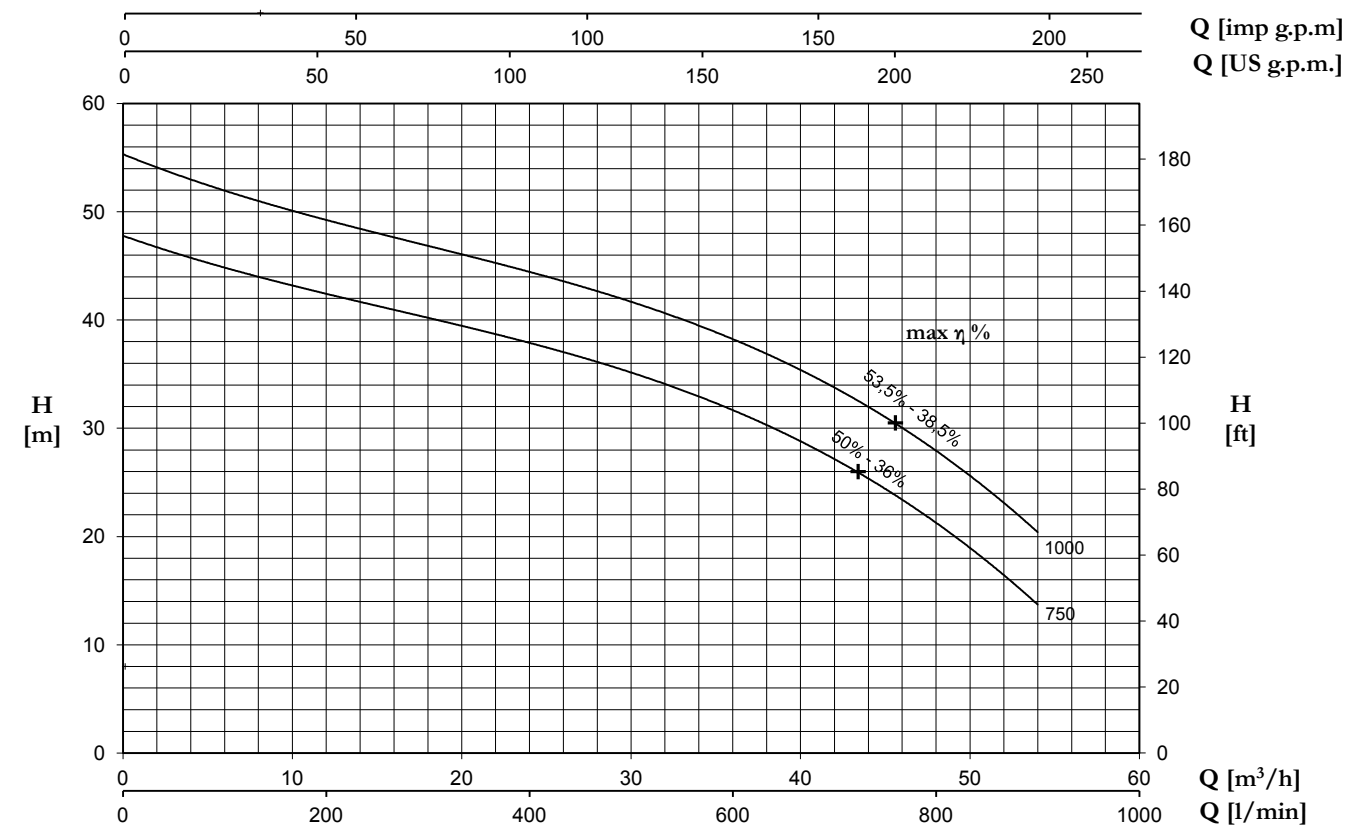

TYPE	AMPERE			
	3x230 V 50 Hz (*)	3x400 V 50 Hz	230/400 V 50 Hz λ / Δ (*)	400/690 V 50 Hz λ / Δ
3~				
FC 750 T	-	15,3	26,5	15,3
FC 1000 T	-	17,5	30,3	17,5

(*) no standard execution

+ max η %

max rendimento idraulico e rispettivo rendimento totale
 max hydraulic efficiency and respective total efficiency
 máx rendimiento hidráulico y correspondiente rendimiento total
 max rendement hydraulique et rendement total

TYPE	P2		P1 (kW)	Q (m³/h - l/min)																
				H (m)																
				0	12	18	24	30	36	42	48	54								
3~	(HP)	(kW)	3~	0	200	300	400	500	600	700	800	900								
FC 750 T	7,5	5,5	9,0	47,6	42,9	40,4	37,7	34,7	31,2	27,4	22,3	13,1								
FC 1000 T	10	7,5	10,3	55,1	49,8	47,1	44,2	41,1	37,8	34	29,1	19,7								

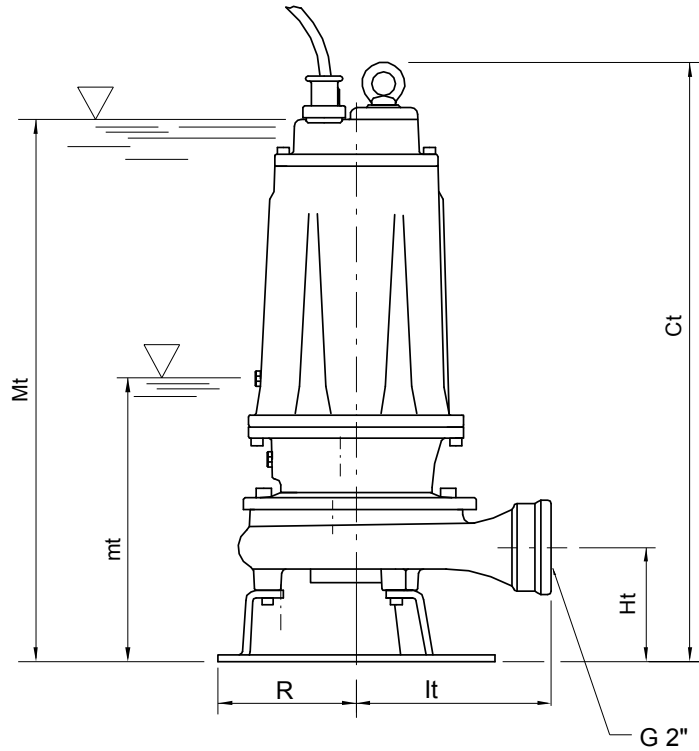

Mt: livello minimo di funzionamento continuo
 Mt: lowest level for continuous duty
 Mt: nivel minimo de funcionamiento continuo
 Mt: niveau minimum de fonctionnement continuu

mt: livello minimo di funzionamento
 mt: lowest working level
 mt: nivel minimo de funcionamiento
 mt: niveau minimum de fonctionnement

TYPE	DIMENSIONS (mm)						DNm	Kg
	Ct	Ht	R	lt	mt	Mt		
FC 160 - FC 160T	513	102	117	174	205	475	2" G	37
FC 210 - FC 210T	513	102	117	174	205	475	2" G	37,5
FC 310T	513	102	117	174	205	475	2" G	37

TYPE	PROTECTION		CONTROL PANEL		
	1 x 230V	3 x 400V	1 x 230V	3 x 400V	400 / 690V
FC 160	PMC 15/35-15	PT 20-30-40/4.3-6.8	QSM + 35µF	QSMT 10	-
FC 210	PMC 20/50-18	PT 20-30-40/4.3-6.8	QSM + 50µF	QSMT 10	-
FC 310T	-	PT 40-50/5.7-9.1	-	QSMT 10	-
FC 410T	-	PT 55-75/8.6-13.5	-	QSMT 10	-
FC 560T	-	PT 55-75/8.6-13.5	-	QSMT 10	-
FC 750T	-	PT 100/12.5-16.5	-	QSMT 10	QST 7
FC 1000T	-	PT 125-150/16-21	-	QSMT 15	QST 7

Mt/Mf: livello minimo di funzionamento continuo
 Mt/Mf: lowest level for continuous duty
 Mt/Mf: nivel minimo de funcionamiento continuo
 Mt/Mf: niveau minimum de fonctionnement continuu

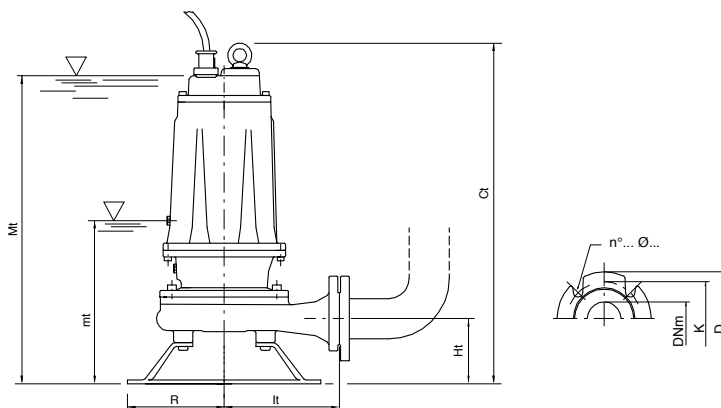

TYPE	DIMENSIONS (mm)							Kg
	Ct	Ht	R	lt	mt	Mt	DNm	
FC 410T	595	112	160	187	263	550	50	60,5
FC 560T	595	112	160	187	263	550	50	63,5
FC 750T	680	160	180	250	280	630	65	91
FC 1000T	680	160	180	250	280	630	65	93,5

mt/mf: livello minimo di funzionamento
 mt/mf: lowest working level
 mt/mf: nivel minimo de funcionamiento
 mt/mf: niveau minimum de fonctionnement

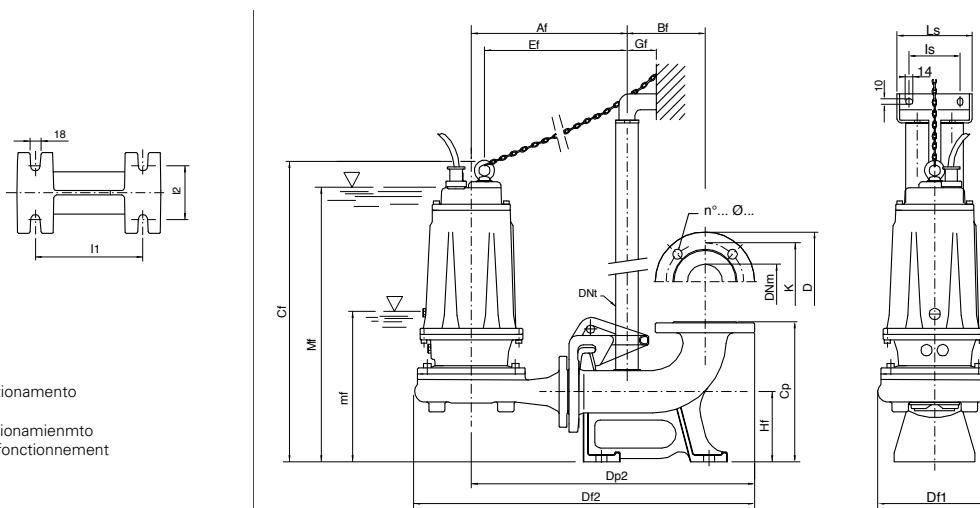

TYPE	DIMENSIONS (mm)																		
	Af	Bf	Cf	Cp	Df1	Df2	Dp2	DNt	Ef	Gf	Hf	I1	I2	Is	Ls	mf	Mf	DNm	
FC 410T / P	300	145	614	260	237	654	535	1" 1/4	269	55	130	200	100	95	140	290	566	50	
FC 560T / P	300	145	614	260	237	654	535	1" 1/4	269	55	130	200	100	95	140	290	566	50	
FC 750T / P	331	145	656	260	279	701	569	1" 1/4	296	55	130	200	100	95	140	290	600	65	
FC 1000T / P	331	145	656	260	279	701	569	1" 1/4	296	55	130	300	100	95	140	290	600	65	

Flange UNI PN 10 (mm)			
DNm	K	D	n°... Ø...
50	125	165	4... 18...
65	145	185	4... 18...

TYPE	TRUCK		CONTAINER	
	PALLET (cm)	N° pumps	PALLET (cm)	N° pumps
	FC 160-310	85X110X145	18	85X110X190
FC 410-560T	85X110X170	12	85X110X170	12
FC 750-1000T	100X120X190	12	100X120X190	12

